

## Air filtration Air filter units with different filtration stages

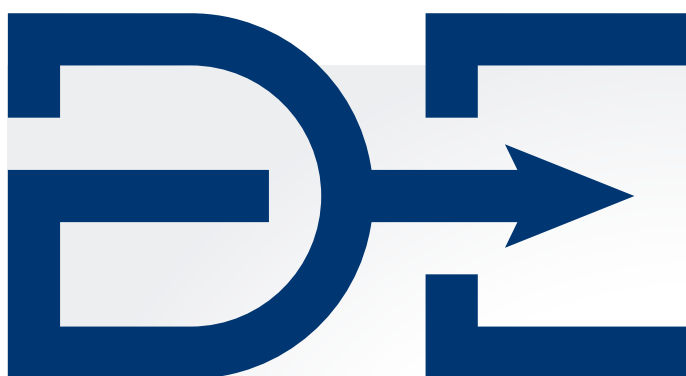

UNITS WITH E.C. TECHNOLOGY MOTOR  
**CAKS/EC/FILTER**

UNITS WITH DIRECT DRIVE  
**CADTM/ALPF**

BELT DRIVEN UNITS WITH IE3 MOTOR  
**CADT/ALPF**



# CAKS/EC/FILTER

Filter units with F9 or HEPA filter for circular ducting, with a 25 mm thick insulating acoustic casing to reduce noise; E.C. Technology motor



## FILTRATION STAGES:

Depending on the model, the units incorporate two filtration stages, F7+F9 or F7+HEPA H14, as well as an active carbon filter for eliminating odours, which provides the unit with an excellent performance in terms of filtration.

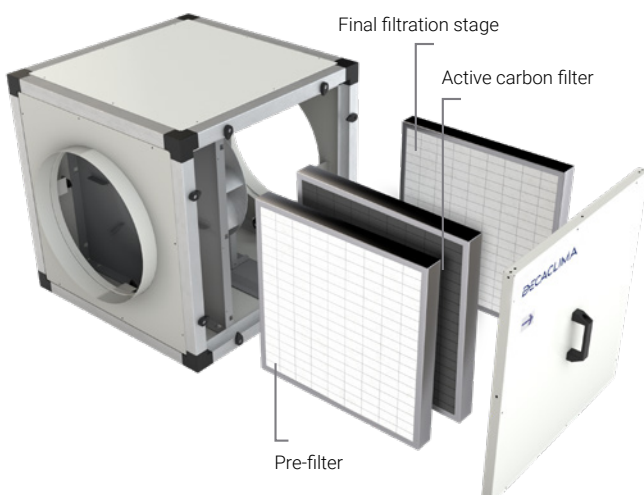

## CHARACTERISTICS:

- Covers with a high quality, 25 mm thick acoustic casing.
- Backward curved impeller.
- Filtration stages depending on the model:
  - F7+F9
  - F7+HEPA H14
  - Active carbon filter for eliminating odours
- Inspection cover for conducting maintenance and replacing the filters.
- Air inlet nozzle with diffusers that increases the efficiency of the fan.

## MOTOR:

- High efficiency E.C. Technology motors with external rotor, regulated by a 0-10 V signal.
- Single-phase 200/240 V-50/60 Hz and three-phase 380/480 V-50/60 Hz.
- Maximum temperature of the air to be carried: -25°C +60°C.

## FINISH:

- Aluminium profile structure and prefinished sheet.

## EXAMPLE OF APPLICATION:

- Purification of indoor air

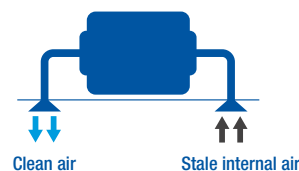

- Collection and purification of indoor air

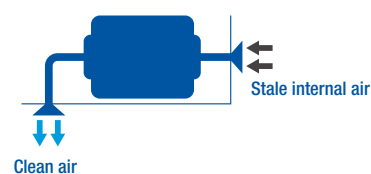

### Characteristics of the filters

Filters	EN 779	EN 1822	ISO 16890			
			ISO ePM <sub>1</sub>	ISO ePM <sub>2.5</sub>	ISO ePM <sub>10</sub>	ISO COARSE
F7	90%	-	>50%	>65-95%	>85%	-
F9	95%	-	>80%	>95%	>95%	-
HEPA H14	-	>99.995%	-	-	-	-

### Technical characteristics

Model	Recommended working surface <sup>1</sup>		Speed (r/min)	Max-imum power (W)	Power supply	Sound pressure level at 50% of max. speed <sup>2</sup> dB (A)	Maximum flow rate		Weight (kg)
	(m <sup>2</sup> ) (F7+F9)	(F7+F14)					(m <sup>3</sup> /h) (F7+F9)	(F7+F14)	
CAKS/EC/FILTER-220	50	-	3265	176	200-240V 50/60Hz 1Ph	48	420	-	32
CAKS/EC/FILTER-250	60	-	2850	180	200-240V 50/60Hz 1Ph	49	500	-	33
CAKS/EC/FILTER-310	65	55	1920	175	200-240V 50/60Hz 1Ph	47	550	450	34
CAKS/EC/FILTER-400	190	155	1550	460	200-240V 50/60Hz 1Ph	47	1600	1300	68
CAKS/EC/FILTER-500	270	230	1250	1150	380-480V 50/60Hz 3Ph	51	2250	1950	118

<sup>1</sup> Recommended surface for a space 3 metres high.

<sup>2</sup> Irradiated sound pressure level in dB (A) at 3 m distance.

### Acoustic characteristics

Sound power level Lw(A) in dB(A) per frequency band in Hz. Irradiated values at maximum speed and medium flow rate.

	63	125	250	500	1000	2000	4000	8000
CAKS/EC/FILTER-220	63	65	63	58	55	51	45	35
CAKS/EC/FILTER-250	64	66	64	59	56	52	46	36
CAKS/EC/FILTER-310	62	64	62	57	54	50	44	34
CAKS/EC/FILTER-400	66	61	56	53	54	49	43	32
CAKS/EC/FILTER-500	69	65	60	61	61	58	59	54

### Dimensions mm

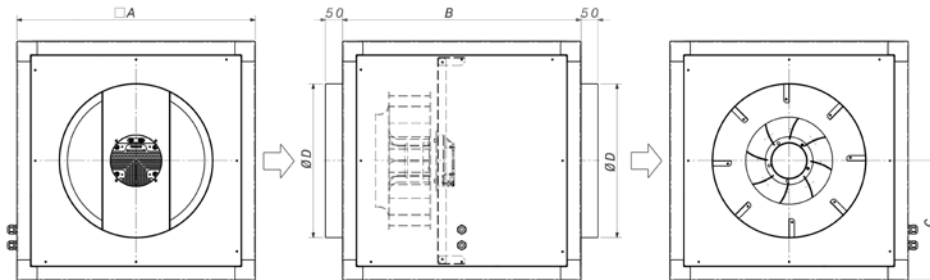

	A	B	C	ØD
CAKS/EC/FILTER-220	500	500	250	315
CAKS/EC/FILTER-250	500	500	250	355
CAKS/EC/FILTER-310	500	500	250	355
CAKS/EC/FILTER-400	700	700	350	450
CAKS/EC/FILTER-500	900	900	450	500

Characteristic curves

Q = Flow rate in m<sup>3</sup>/h, m<sup>3</sup>/s and cfm.  
 Pe = Static pressure in mmH<sub>2</sub>O, Pa and inwg.

CAKS/EC/FILTER-220

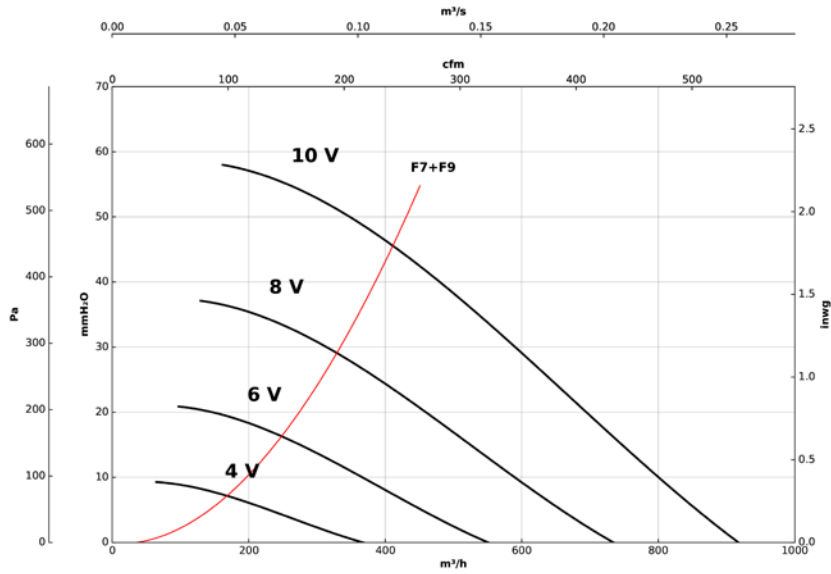

CAKS/EC/FILTER-250

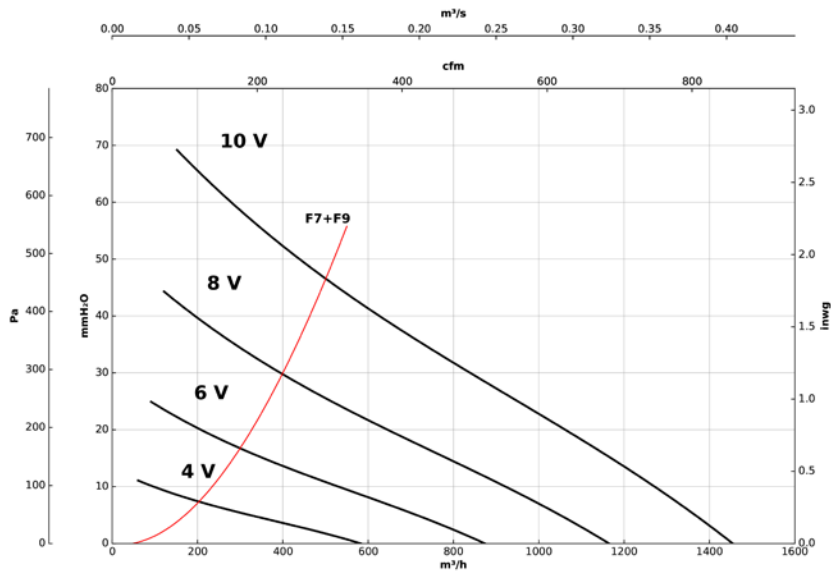

CAKS/EC/FILTER-310

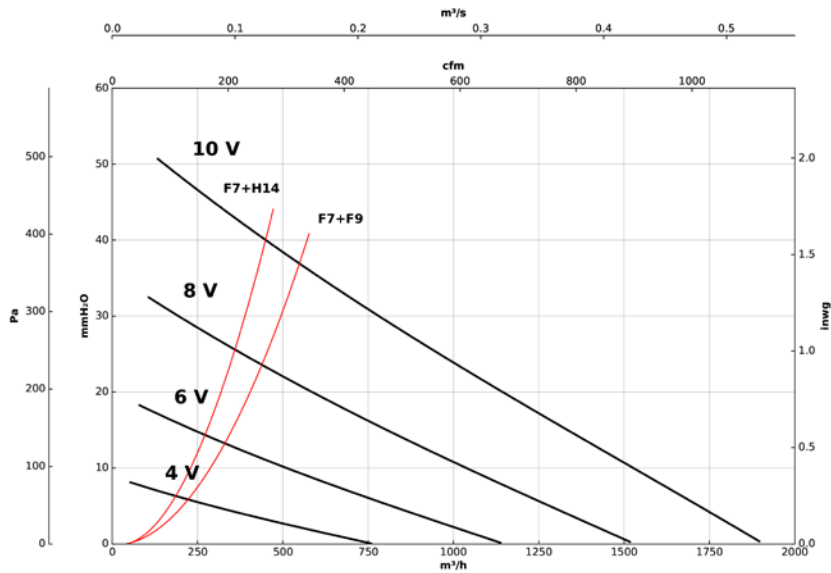

Characteristic curves

Q = Flow rate in m<sup>3</sup>/h, m<sup>3</sup>/s and cfm.  
 Pe = Static pressure in mmH<sub>2</sub>O, Pa and inwg.

CAKS/EC/FILTER-400

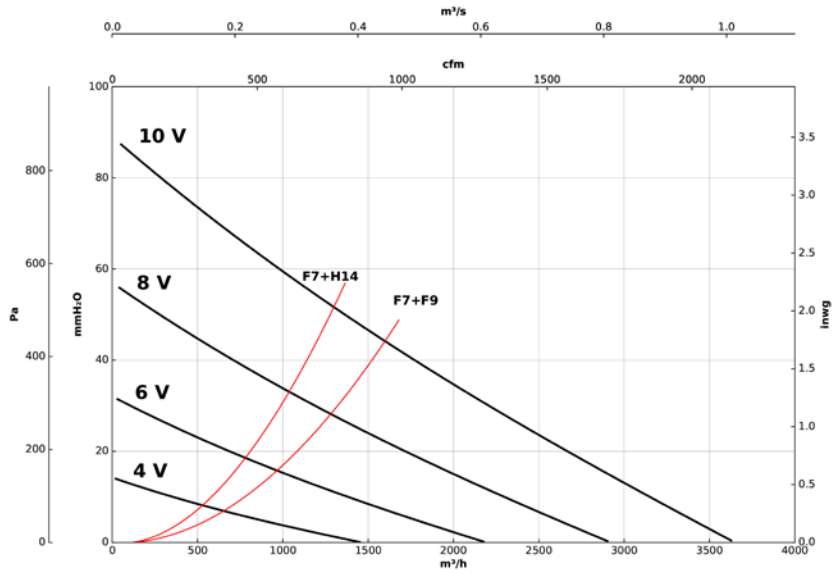

CAKS/EC/FILTER-500

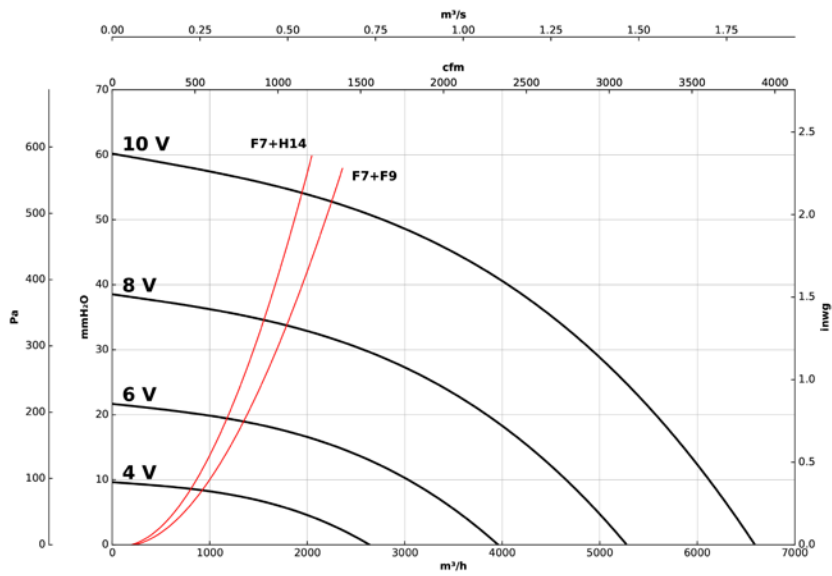

# CADTM/ALPF

Ventilation units with prefinished sheet steel, built-in filters and aluminium profiles



## FAN:

- Aluminium profiles structure with thermal and acoustic insulation.
- Action impeller made of galvanised sheet steel.
- Cable gland for cable inlet.
- Double inlet, DTM series fans.

## MOTOR:

- Closed motors with built-in thermal protector, class F, with ball bearings, IP54 protection.
- Single-phase 220/240 V -50Hz and three-phase 220-240/380-415 V -50Hz.
- Maximum temperature of the air to be carried: -20°C+ 60°C.

## FINISH:

- Anti-corrosive prefinished sheet steel and aluminium profiles.

## UPON REQUEST:

- With circular air supply.

## Technical characteristics of the fan without filter

Model		Speed (r/min)	Maximum admissible current (A)		Installed power (kW)	Maximum flow rate (m³/h)	Sound pressure level dB (A)	Approx. weight (kg)	According ErP
			230 V	400 V					
CADTM/ALPF	7/7-4M 1/5	1320	1.15		0.15	1500	58	22.5	2018
CADTM/ALPF	7/7-6M 1/10	820	0.85		0.08	1230	53	22.5	2018
CADTM/ALPF	9/9-4M 1/2	1320	2.30		0.37	2800	66	31.8	2018
CADTM/ALPF	9/9-4M 3/4	1310	3.65		0.55	3600	70	32.6	2018
CADTM/ALPF	9/9-6M 1/5	850	1.50		0.15	2200	60	30.1	2018
CADTM/ALPF	9/9-6M 1/3	940	1.60		0.25	2700	61	31.3	2018
CADTM/ALPF	10/10-4M 1/2	1320	2.30		0.37	2800	65	37.3	2018
CADTM/ALPF	10/10-4M 3/4	1310	3.65		0.55	3950	70	38.1	2018
CADTM/ALPF	10/10-6M 1/3	940	1.60		0.25	3200	61	36.8	2018
CADTM/ALPF	12/12-6T 1 1/2	850	6.60	3.80	1.10	7800	74	53.8	2018
CADTM/ALPF	12/12-6M 3/4	930	3.30		0.55	4750	63	52.3	2018
CADTM/ALPF	12/12-6M 1	850	5.37		0.75	6000	70	53.3	2018
CADTM/ALPF	15/15-6T 3	890	10.90	6.30	2.20	11400	74	80.0	2018

To calculate the final flow rate, add the load loss introduced by the chosen filter

### Acoustic characteristics

Sound power level Lw(A) in dB(A) per frequency band in Hz

Model	63	125	250	500	1000	2000	4000	8000
7/7-4M 1/5	43	54	58	62	64	63	62	53
7/7-6M 1/10	38	49	53	57	59	58	57	48
9/9-4M 1/2	51	62	66	70	72	71	70	61
9/9-4M 3/4	55	66	70	74	76	75	74	65
9/9-6M 1/5	44	55	59	63	65	64	63	54
9/9-6M 1/3	46	57	61	65	67	66	65	56
10/10-4M 1/2	50	61	65	69	71	70	69	60

Model	63	125	250	500	1000	2000	4000	8000
10/10-4M 3/4	55	66	70	74	76	75	74	65
10/10-6M 1/3	46	57	61	65	67	66	65	56
12/12-6T 1 1/2	59	70	74	78	80	79	78	69
12/12-6M 3/4	48	59	63	67	69	68	67	58
12/12-6M 1	55	66	70	74	76	75	74	65
15/15-6T 3	61	72	77	81	83	81	80	71

### Dimensions mm

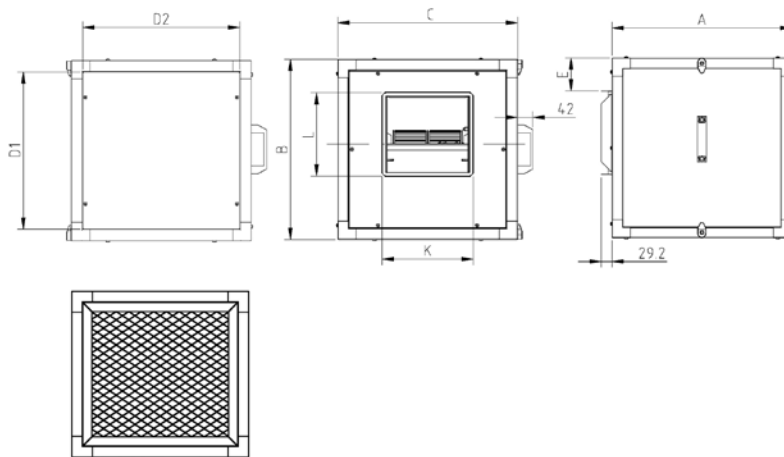

	A	B	C	D1	D2	E	L	K
CADTM/ALPF 7/7	490	490	490	428	428	91	226	247
CADTM/ALPF 9/9	550	550	550	488	488	86	279	317
CADTM/ALPF 10/10	605	605	605	543	543	88	306	343
CADTM/ALPF 12/12	680	680	680	618	618	84	360	404
CADTM/ALPF 15/15	855	855	855	793	793	119	423	490

**Characteristic curves of the fan without filter**

Q = Flow rate in m<sup>3</sup>/h, m<sup>3</sup>/s and cfm.

Pe = Static pressure in mmH<sub>2</sub>O, Pa and inwg.

To calculate the final flow rate, add the load loss introduced by the chosen filter

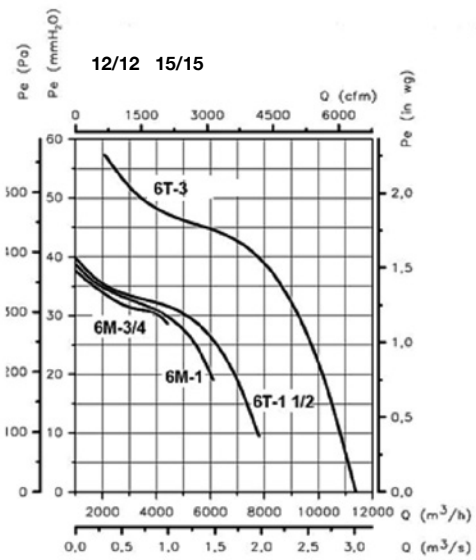
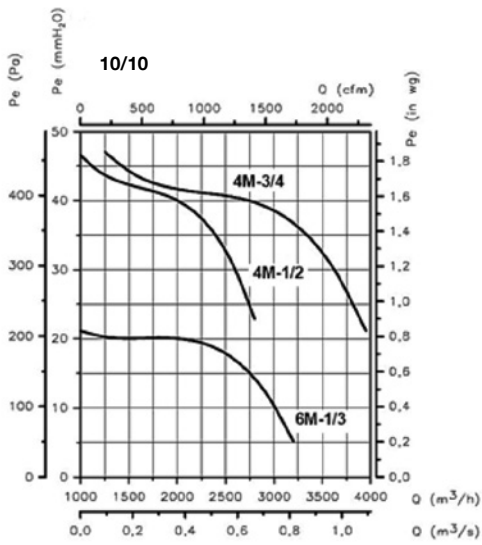
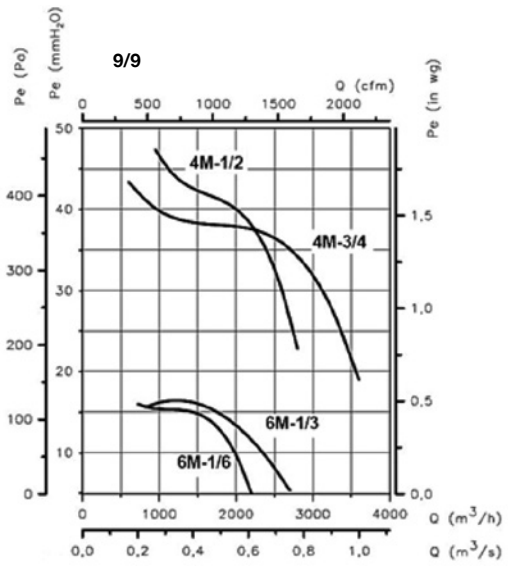
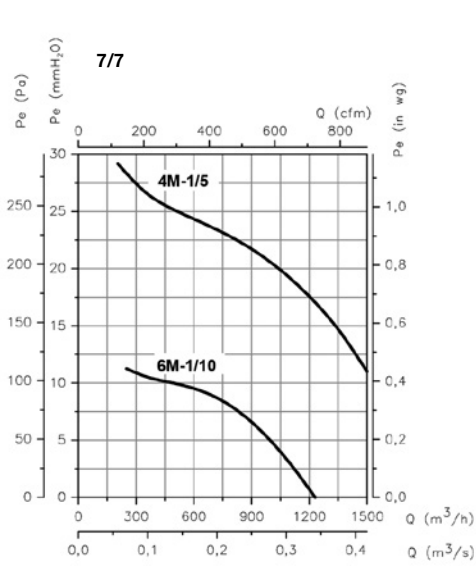

**Load loss curves of units with filters**

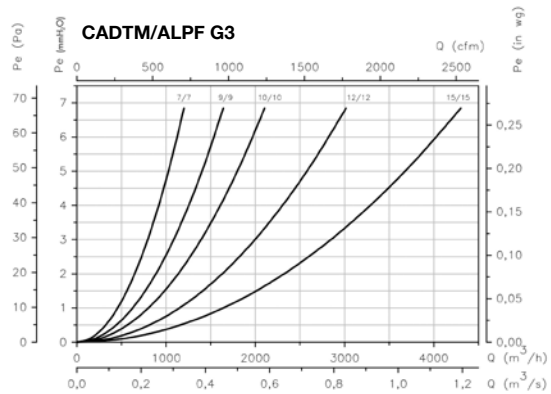
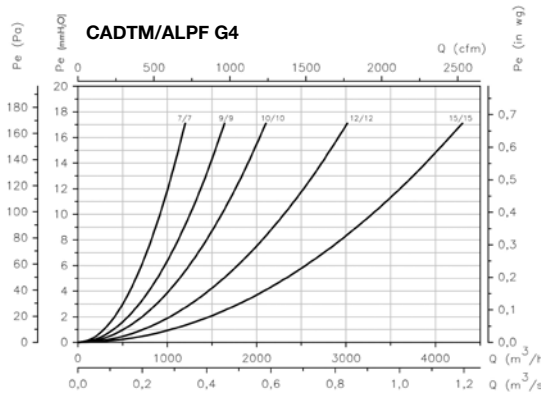



# CADT/ALPF

Belt-driven ventilation units with prefinished sheet steel, built-in filters and aluminium profiles



### FAN:

- Ventilation units fitted with double-inlet fans from the DTS, DTC and DTR series.
- Aluminium profiles structure with thermal and acoustic insulation.
- Action impeller made of galvanised sheet steel.
- Cable gland for cable inlet.

### MOTOR:

- IE3 efficiency motors for powers equal to or higher than 0.75 kW except single-phase, 2-speed and 8-pole.
- Class F motors with ball bearings and IP55 protection.
- Three-phase 230/400 V - 50 Hz (up to 4 kW) and 400/690 V - 50 Hz. (powers higher than 4kW)
- Maximum temperature of the air to be carried: -20°C+ 60°C.

### FINISH:

- Anti-corrosive prefinished sheet steel and aluminium profiles.

### UPON REQUEST:

- With circular air supply.

## Technical characteristics of the fan without filter

Model	Speed (r/min)	Maximum admissible current			Installed power (kW)	Maximum flow rate (m³/h)	Sound pressure level dB (A)	Approx. weight (kg)	Mounting version	According ErP
		230 V	(A) 400 V	690 V						
CADT/ALPF	7/7-0.75	1400	2.92	1.69	0.55	1200	56	41	A	2018
CADT/ALPF	7/7-1 IE3	1600	3.10	1.79	0.75	1450	58	43	A	2018
CADT/ALPF	9/9-0.25	825	1.23	0.71	0.18	1700	45	48	A	2018
CADT/ALPF	9/9-0.33	920	1.66	0.96	0.25	1800	48	50	A	2018
CADT/ALPF	9/9-0.5	1020	2.02	1.17	0.37	2200	51	52	A	2018
CADT/ALPF	9/9-0.75	1050	2.92	1.69	0.55	2900	55	55	A	2018
CADT/ALPF	9/9-1 IE3	1070	3.10	1.79	0.75	3200	56	56	A	2018

To calculate the final flow rate, add the load loss introduced by the chosen filter

### Technical characteristics of the fan without filter

Model	Speed	Maximum admissible current			Installed power	Maximum flow rate	Sound pressure level	Approx. weight	Mounting version	According ErP
		(r/min)	230 V	(A) 400 V						
CADT/ALPF	9/9-1.5 IE3	1260	4.03	2.32	1.10	3750	60	59	A	2018
CADT/ALPF	10/10-0.75	845	2.92	1.69	0.55	3800	56	57	A	2018
CADT/ALPF	10/10-1 IE3	960	3.10	1.79	0.75	4175	58	59	A	2018
CADT/ALPF	10/10-1.5 IE3	1070	4.03	2.32	1.10	4800	61	61	A	2018
CADT/ALPF	10/10-2 IE3	1140	5.96	3.44	1.50	5400	63	65	A	2018
CADT/ALPF	12/12-0.5	595	2.02	1.17	0.37	4200	52	69	A	2018
CADT/ALPF	12/12-0.75	675	2.92	1.69	0.55	4800	54	71	A	2018
CADT/ALPF	12/12-1 IE3	765	3.10	1.79	0.75	5400	57	72	A	2018
CADT/ALPF	12/12-1.5 IE3	855	4.03	2.32	1.10	5800	59	75	A	2018
CADT/ALPF	12/12-2 IE3	965	5.96	3.44	1.50	6500	62	79	A	2018
CADT/ALPF	12/12-3 IE3	1180	8.36	4.83	2.20	7400	65	87	B	2018
CADT/ALPF	15/15-0.75	525	2.92	1.69	0.55	5900	49	85	B	2018
CADT/ALPF	15/15-1 IE3	595	3.10	1.79	0.75	6500	52	86	B	2018
CADT/ALPF	15/15-1.5 IE3	635	4.03	2.32	1.10	7500	54	89	B	2018
CADT/ALPF	15/15-2 IE3	670	5.96	3.44	1.50	8200	56	93	B	2018
CADT/ALPF	15/15-3 IE3	740	8.36	4.83	2.20	9500	59	101	B	2018
CADT/ALPF	15/15-4 IE3	805	10.96	6.33	3.00	10600	61	103	B	2018
CADT/ALPF	18/18-1.5 IE3	480	4.03	2.32	1.10	9000	48	122	B	2018
CADT/ALPF	18/18-2 IE3	605	5.96	3.44	1.50	9250	51	125	B	2018
CADT/ALPF	18/18-3 IE3	590	8.36	4.83	2.20	11500	54	134	B	2018
CADT/ALPF	18/18-4 IE3	640	10.96	6.33	3.00	13200	56	136	B	2018
CADT/ALPF	18/18-5.5 IE3	675	14.10	8.12	4.00	15000	58	141	C	2018
CADT/ALPF	18/18-7.5 IE3	760		11.60 6.72	5.50	17000	60	155	C	2018
CADT/ALPF	20/20-2 IE3	430	5.96	3.44	1.50	11500	56	222	C	2018
CADT/ALPF	20/20-3 IE3	530	8.36	4.83	2.20	12800	57	231	C	2018
CADT/ALPF	20/20-4 IE3	575	10.96	6.33	3.00	14200	58	233	C	2018
CADT/ALPF	20/20-5.5 IE3	635	14.10	8.12	4.00	15500	61	238	C	2018
CADT/ALPF	20/20-7.5 IE3	675		11.60 6.72	5.50	17500	63	252	C	2018
CADT/ALPF	20/20-10 IE3	725		13.90 8.06	7.50	20000	65	283	C	2018
CADT/ALPF	22/22-2 IE3	385	5.96	3.44	1.50	14000	50	250	C	2018
CADT/ALPF	22/22-3 IE3	475	8.36	4.83	2.20	15000	54	257	C	2018
CADT/ALPF	22/22-4 IE3	515	10.96	6.33	3.00	17000	55	261	C	2018
CADT/ALPF	22/22-5.5 IE3	570	14.10	8.12	4.00	19000	57	265	C	2018
CADT/ALPF	22/22-7.5 IE3	605		11.60 6.72	5.50	21500	60	279	C	2018
CADT/ALPF	22/22-10 IE3	675		13.90 8.06	7.50	25000	63	306	C	2018
CADT/ALPF	22/22-15 IE3	765		20.90 12.10	11.00	27000	65	341	C	2018
CADT/ALPF	25/25-3 IE3	375	8.36	4.83	2.20	17000	53	297	C	2018
CADT/ALPF	25/25-4 IE3	405	10.96	6.33	3.00	20500	55	299	C	2018
CADT/ALPF	25/25-5.5 IE3	450	14.10	8.12	4.00	22000	57	304	C	2018
CADT/ALPF	25/25-7.5 IE3	485		11.60 6.72	5.50	24500	59	318	C	2018
CADT/ALPF	25/25-10 IE3	545		13.90 8.06	7.50	28000	61	345	C	2018
CADT/ALPF	25/25-15 IE3	610		20.90 12.10	11.00	32000	64	374	C	2018
CADT/ALPF	30/28-3 IE3	330	8.36	4.83	2.20	20000	54	380	C	2018
CADT/ALPF	30/28-4 IE3	360	10.96	6.33	3.00	22000	56	382	C	2018
CADT/ALPF	30/28-5.5 IE3	380	14.10	8.12	4.00	25000	59	387	C	2018
CADT/ALPF	30/28-7.5 IE3	380		11.60 6.72	5.50	31500	60	402	C	2018
CADT/ALPF	30/28-10 IE3	410		13.90 8.06	7.50	36000	63	431	C	2018
CADT/ALPF	30/28-15 IE3	430		20.90 12.10	11.00	42000	65	451	C	2018
CADT/ALPF	30/28-20 IE3	480		27.90 16.20	15.00	48000	68	466	C	2018

Dimensions mm

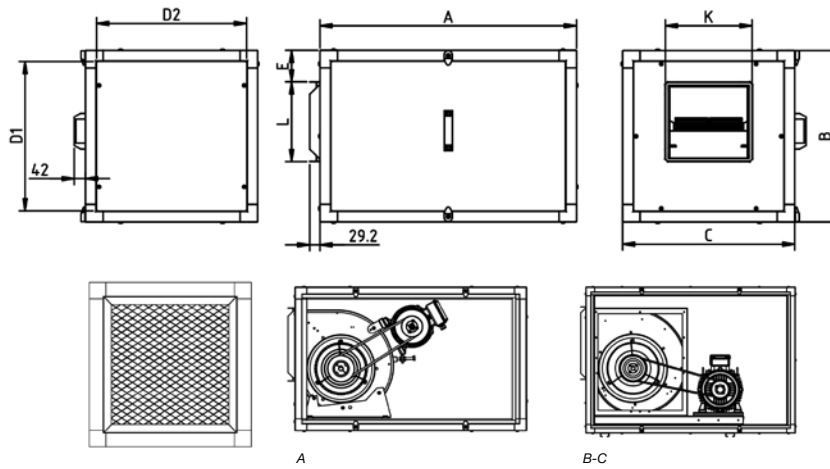

	A	B	C	D1	D2	E	L	K	Installation
CADT/ALPF 7/7	830	490	490	428	428	91	226	247	A
CADT/ALPF 9/9	920	550	550	488	488	86	279	317	A
CADT/ALPF 10/10	970	605	605	543	543	88	306	343	A
CADT/ALPF 12/12	1050	680	680	618	618	84	360	404	A-B
CADT/ALPF 15/15	1220	855	855	793	793	119	423	490	B
CADT/ALPF 18/18	1356	1000	1000	938	938	137	498	554	B-C
CADT/ALPF 20/20	1500	1195	1195	1115	1115	140	615	615	C
CADT/ALPF 22/22	1600	1250	1250	1170	1170	104	705	668	C
CADT/ALPF 25/25	1870	1450	1450	1370	1370	200	792	767	C
CADT/ALPF 30/28	1975	1670	1670	1590	1590	188	938	896	C

Characteristic curves of the fan without filter

Q = Flow rate in m<sup>3</sup>/h, m<sup>3</sup>/s and cfm.

Pe = Static pressure in mmH<sub>2</sub>O, Pa and inwg.

To calculate the final flow rate, add the load loss introduced by the chosen filter

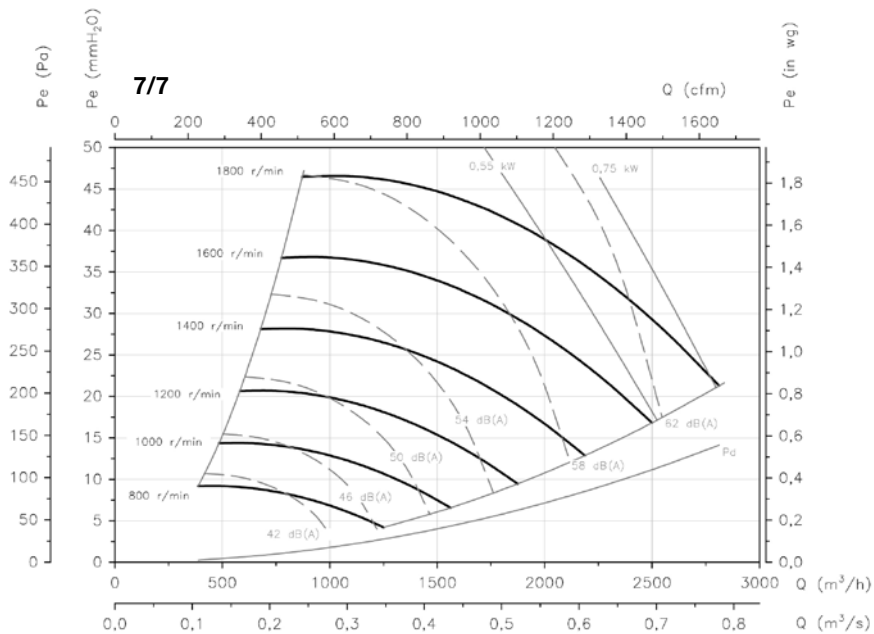

**Characteristic curves of the fan without filter**

Q = Flow rate in m<sup>3</sup>/h, m<sup>3</sup>/s and cfm.

Pe = Static pressure in mmH<sub>2</sub>O, Pa and inwg.

To calculate the final flow rate, add the load loss introduced by the chosen filter

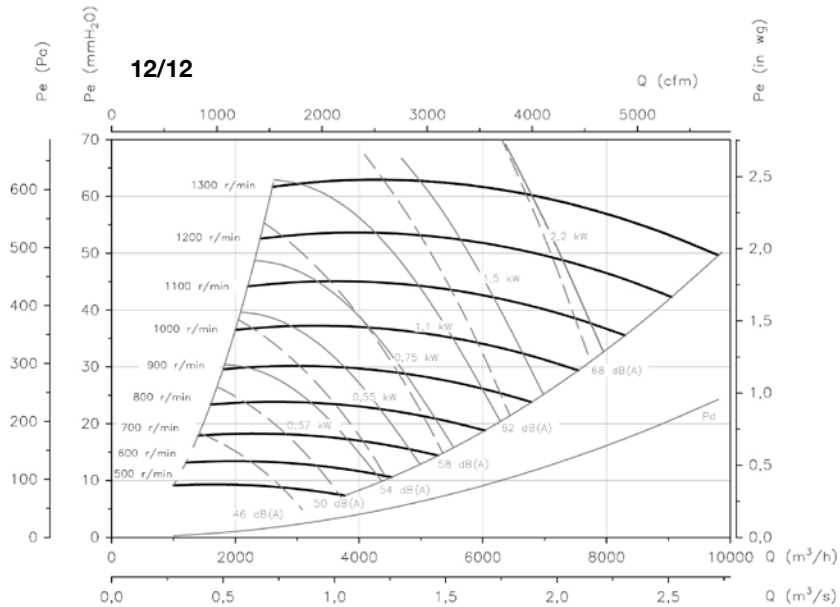
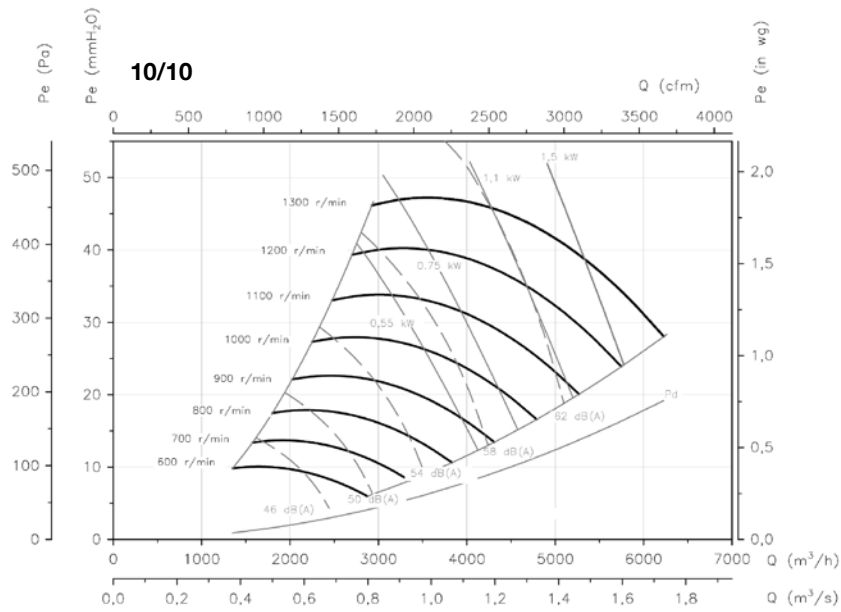
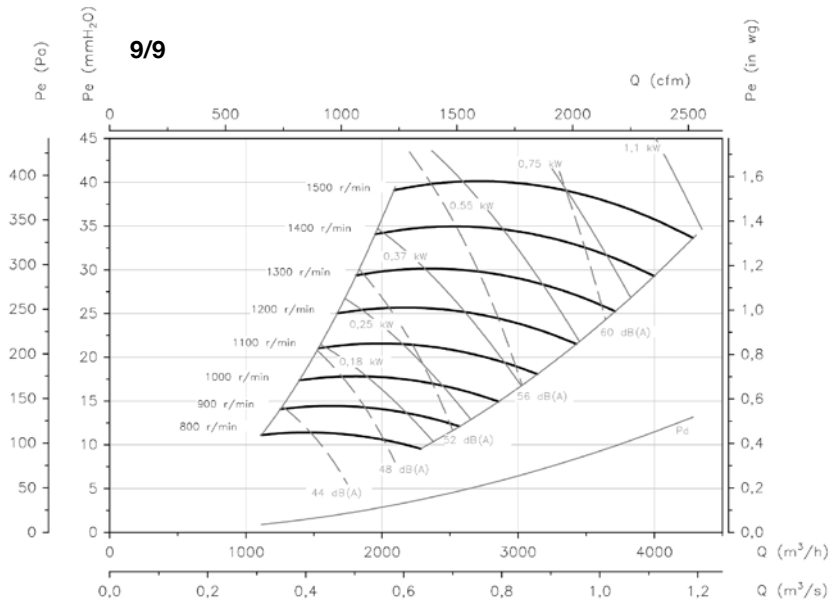

Characteristic curves of the fan without filter

Q = Flow rate in m<sup>3</sup>/h, m<sup>3</sup>/s and cfm.

Pe = Static pressure in mmH<sub>2</sub>O, Pa and inwg.

To calculate the final flow rate, add the load loss introduced by the chosen filter

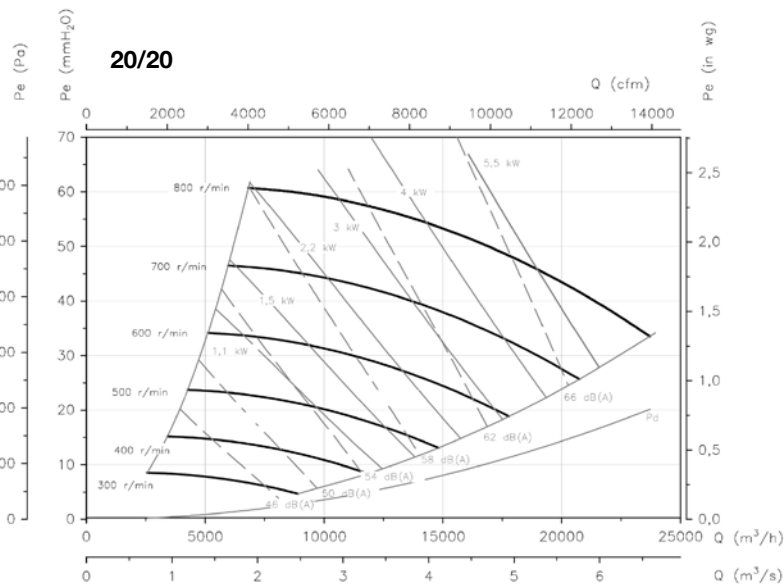
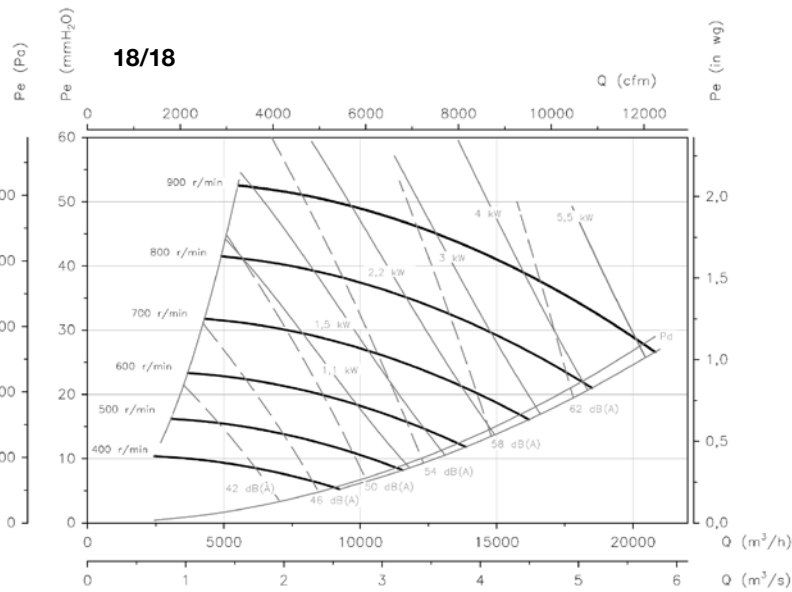
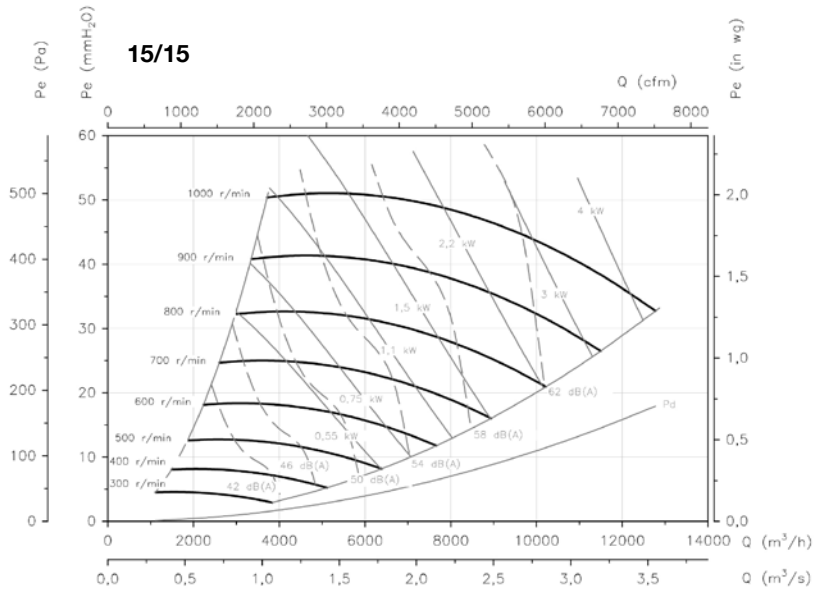

**Characteristic curves of the fan without filter**

Q = Flow rate in m<sup>3</sup>/h, m<sup>3</sup>/s and cfm.

Pe = Static pressure in mmH<sub>2</sub>O, Pa and inwg.

To calculate the final flow rate, add the load loss introduced by the chosen filter

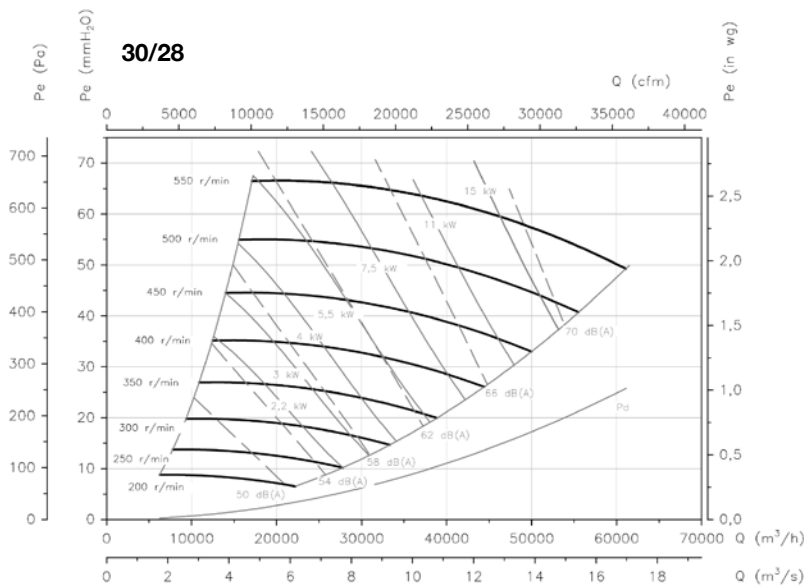
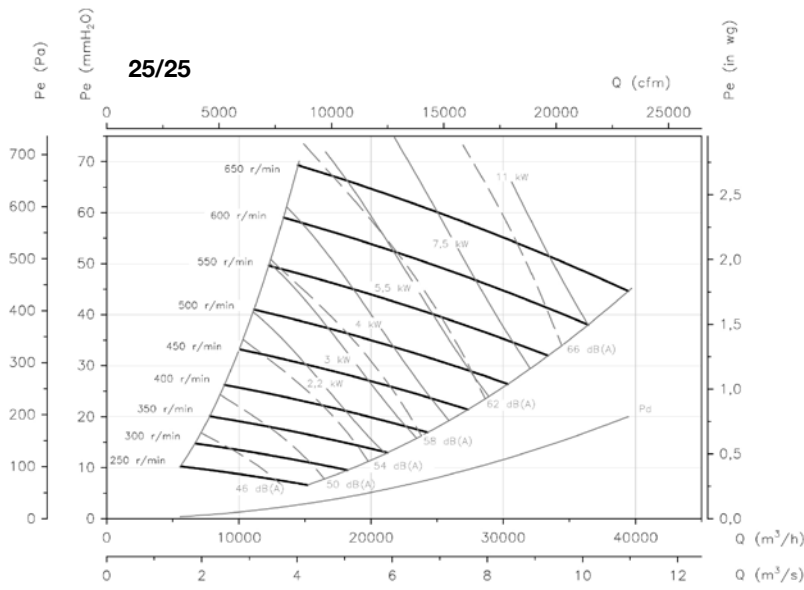
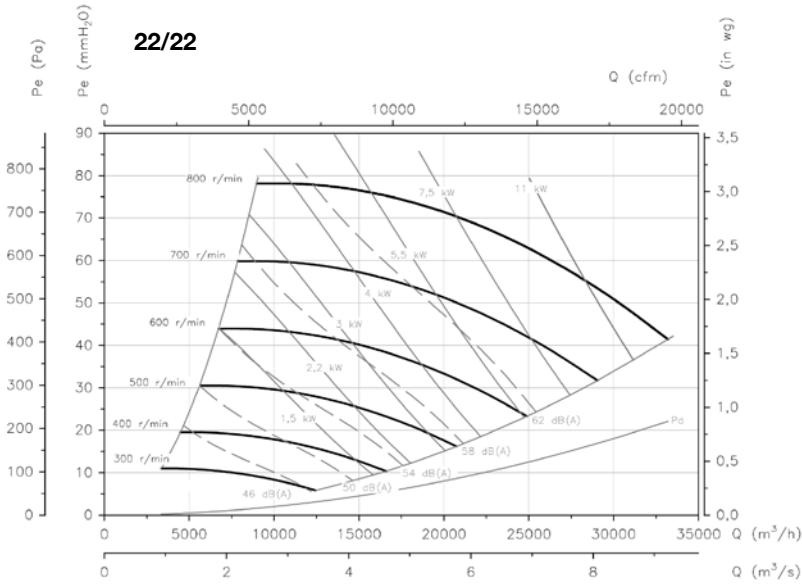

**Characteristic curves of the fan without filter**

Q = Flow rate in m<sup>3</sup>/h, m<sup>3</sup>/s and cfm.

Pe= Static pressure in mmH<sub>2</sub>O, Pa and inwg.

To calculate the final flow rate, add the load loss introduced by the chosen filter

**Load loss curves of units with filters**

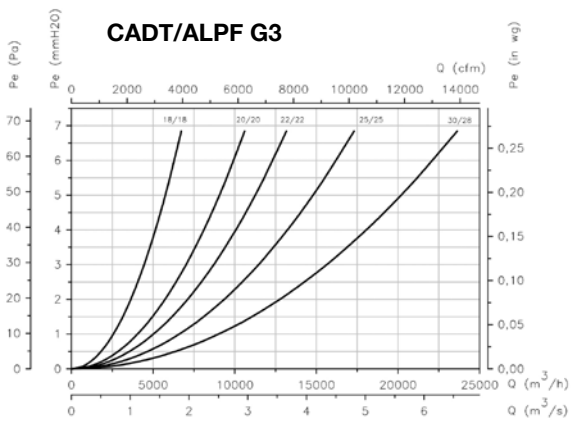
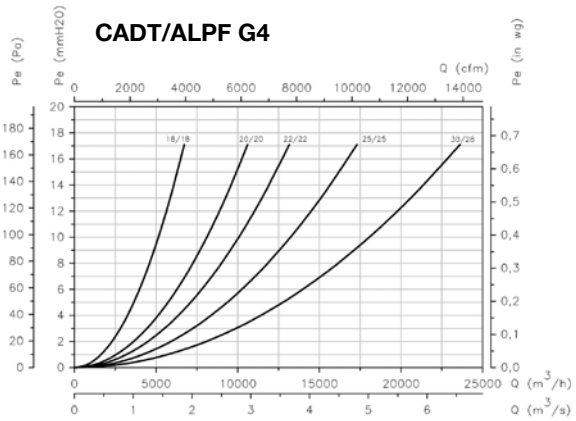
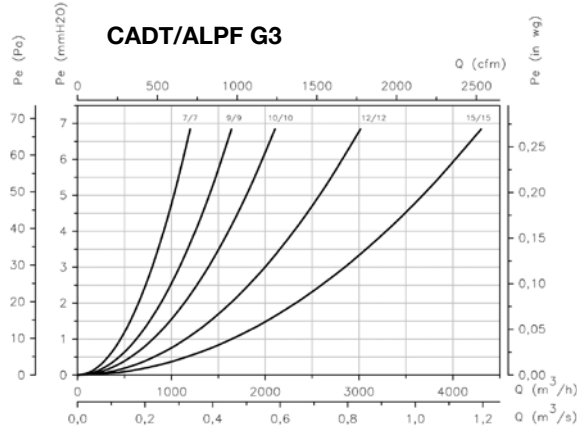
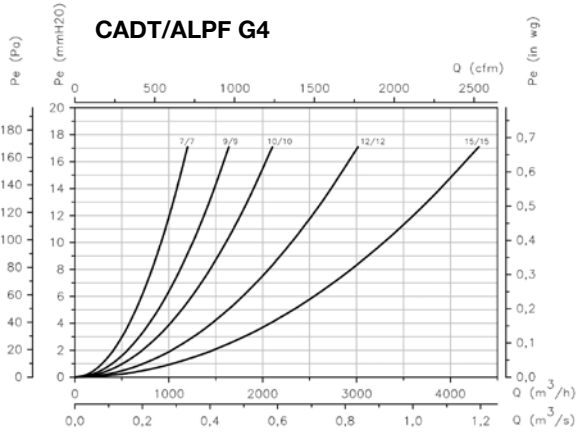

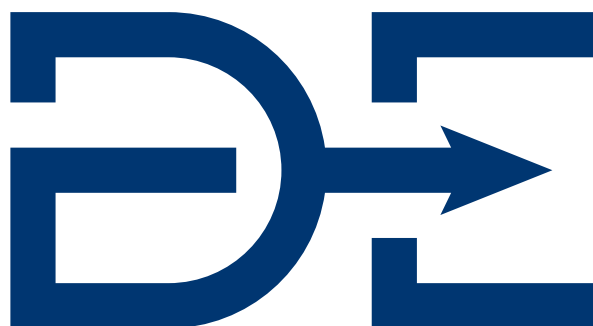

INNOVATION IN AIR CONDITIONING  
AND AIR QUALITY EQUIPMENT

**DECACLIMA**

**DECACLIMA COMFORT SOLUTIONS, S.L.**  
Avda. del Castell, 31  
08570 Torelló (Barcelona)  
Tel. +34 930 130 703  
info@decaclima.com  
[www.decaclima.com](http://www.decaclima.com)

**SODECA** Group